

DANIELS FOOD EQUIPMENT

DVTS 300 AND 500 VACUUM TUMBLER

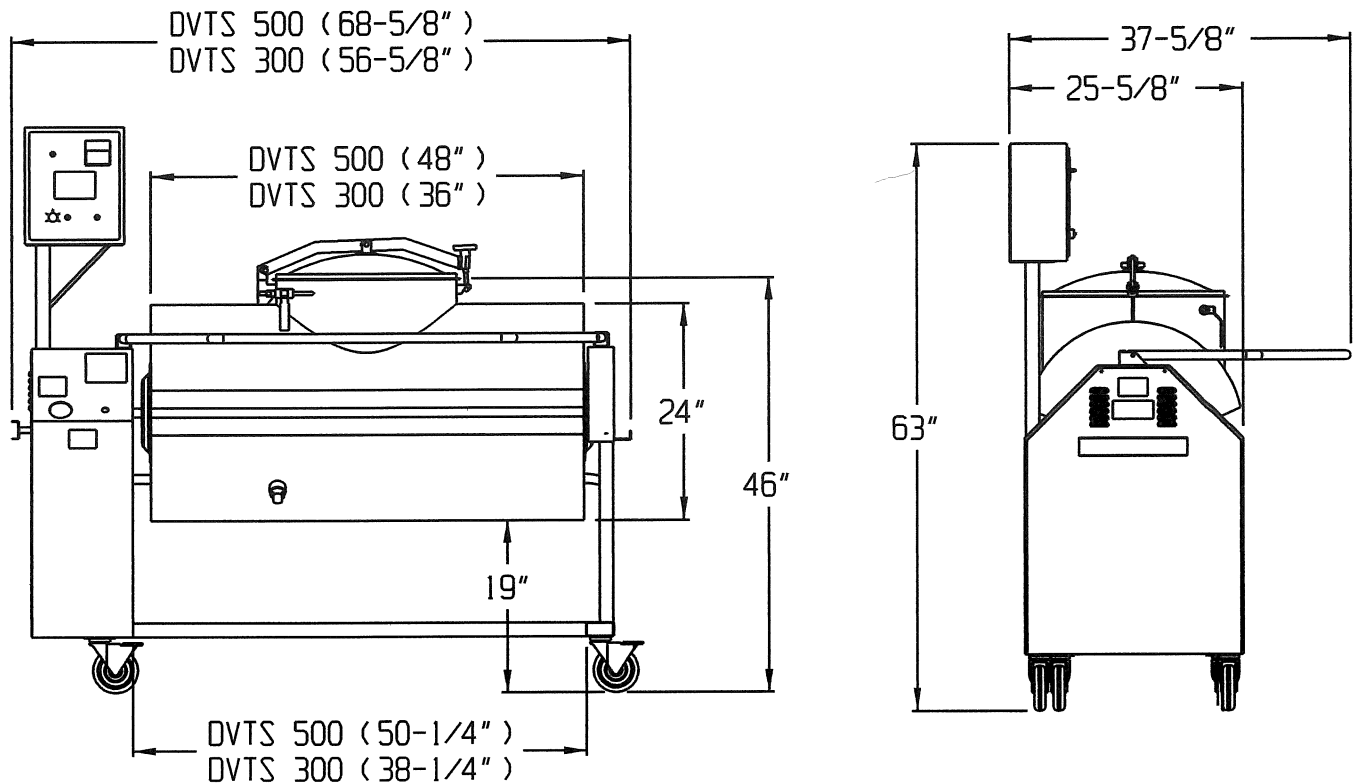

SPECIFICATIONS

TOTAL POWER INPUT:	12-1/2 AMP, 115 VOLT, 60 HZ, 1 PHASE
TUMBLER DRIVE DC:	VARIABLE SPEED CONTROL, FWD/OFF/REV
DRIVE MOTOR:	1/2 HP, DC.
VACUUM PUMP:	1/4 HP 115 VOLT, 60 HZ, 1 PHASE
TIMER:	SX 160 DIGITAL TIMER, HOURS, MINUTES
ELECTRONIC CONTROLS:	TUMBLER SPEED-ADJUSTABLE 0-15 RPM "JOG"- "RUN" TOGGLE SWITCH, "FWD"- "REV" TOGGLE SWITCH, "START"- "STOP" TOGGLE SWITCH, VACUUM PUMP "START"- "STOP" TOGGLE SWITCH
MAXIMUM CAPACITY:	DVTS 500 (550-LBS.) DVTS 300 (420-LBS.)
WEIGHT:	DVTS 500, 400-LBS. (NET) DVTS 300, 365 LBS (NET)

DANIELS FOOD EQUIPMENT

310 NORTH CLAYBORN AVE. PARKERS PRAIRIE, MN. 56361 PHONE: (218) 338-5000 FAX (218) 338-5909.

WEB: www.danielsfood.com

E-MAIL: danielsfood@midwestinfo.net