

# **DANIELS FOOD EQUIPMENT**

## **DVTS 2000 AND 3000 TUMBLER**

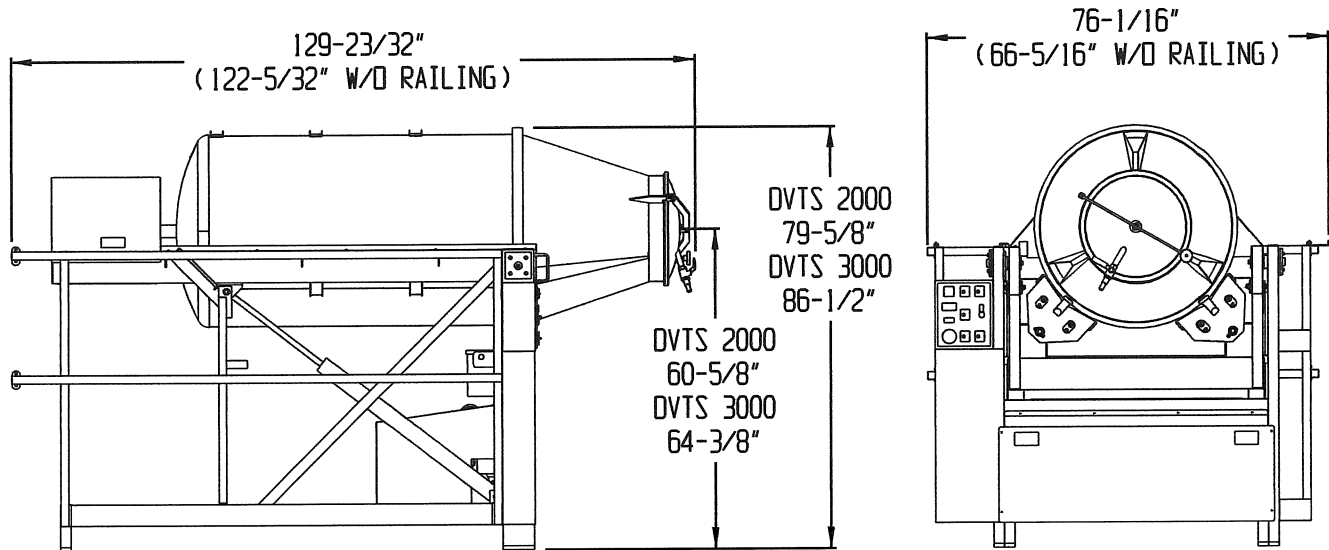

### **SPECIFICATIONS**

<b>STANDARD MOTOR:</b>	<b>5HP, 208/230/460 VOLT, 13.7/12.6/6.3 AMPS, 60 HZ, 3 PHASE</b>
<b>TUMBLER DRIVE:</b>	<b>HYDRAULIC DRIVE</b>
<b>VACUUM PUMP:</b>	<b>1-1/2 HP, 208/230/460 VOLT, 3 PHASE, 5.4/5/2.5 AMPS, CAPACITY 5 CUBIC FEET PER MIN @ 20" Hg</b>
<b>TUMBLER CONTROLS:</b>	<b>VARIABLE SPEED CONTROL, 16 RPM MAX, FORWARD AND REVERSE, TUMBLER LIFT AND LOWER, TACHOMETER, HOUR METER, VACUUM GAUGE, TIMER: MINUTES AND HOURS UP TO 99 HOURS</b>
<b>IDEAL TUMBLING CAPACITY:</b>	<b>(DVTS 2000; 2000 LBS.) (DVTS 3000; 3000 LBS.)</b>
<b>MAXIMUM CAPACITY:</b>	<b>(DVTS 2000; 2600 LBS.) (DVTS 3000; 3500 LBS.)</b>
<b>OPTIONAL MOTORS:</b>	<b>208 Volt, 60 Hz, 3 Phase, 15.5 Amp 460 Volt, 60 Hz, 3 Phase, 7.2 Amp 380 Volt, 50 Hz, 3 Phase, 10.1 Amp</b>

### **DANIELS FOOD EQUIPMENT**

**310 NORTH CLAYBORN AVE. PARKERS PRAIRIE, MN. 56361 PHONE: (218) 338-5000 FAX (218) 338-5909.**

**WEB: [www.danielsfood.com](http://www.danielsfood.com)**

**E-MAIL: [danielsfood@midwestinfo.net](mailto:danielsfood@midwestinfo.net)**