

DANIELS FOOD EQUIPMENT

DMX and DMX QUAD 200 HD SERIES MIXER

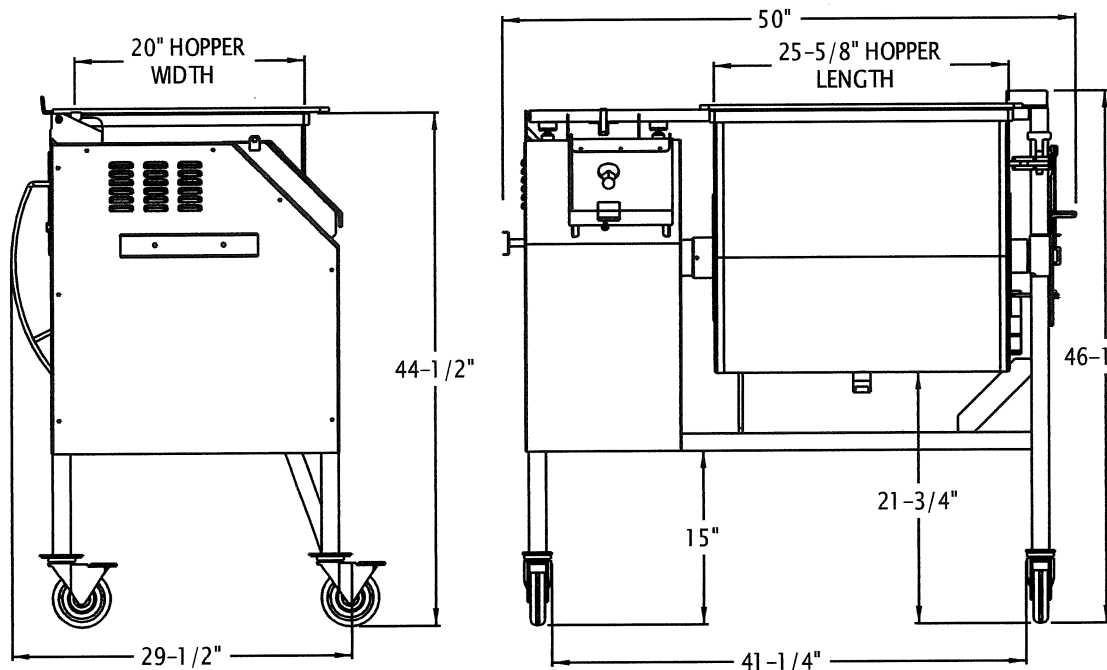

SPECIFICATIONS

MOTOR:	STANDARD: 3 HP, 3 PH, 230 VOLT, 60 Hz, 8.8 AMP OPTIONAL: 3HP, 3PH, 208 VOLT, 60 Hz, 9.0 AMP OPTIONAL: 3 HP, 3 PH, 460 VOLT, 60 Hz, 4.4 AMP
DRIVE SYSTEM:	#50 SPROCKETS & CHAIN, HEAVY DUTY CONSTRUCTED STAINLESS STEEL PADDLES
PADDLE RPM:	DMX 200 HD: 29 RPM DMX 200 QUAD HD: INNER 29 RPM, OUTER 29 RPM
TIMER:	LED READOUT – HOURS and MINUTES
DIRECTION CONTROL:	FORWARD-STOP-REVERSE
HOPPER CAPACITY:	200-LBS.
HOPPER CONSTRUCTION:	12 GA STAINLESS STEEL, 110° DUMPING, REMOVABLE PADDLE, CLEANOUT DRAIN ON BOTTOM, TRANSPARENT COVER WITH SAFETY LOCKOUT.
FRAME:	11 GA STAINLESS STEEL TUBING, OPEN UNDER HOPPER FOR EASY DUMPING, LOCKING SWIVEL CASTERS.
DUMP HEIGHT:	17-3/4"
WEIGHT:	DMX 200 HD: 440-LBS (NET), 490-LBS (SHIPPING), SIZE: 52"L X 32"W X 48"H DMX 200 QUAD HD: 460-LBS (NET), 510-LBS (SHIPPING), SIZE: 52"L X 32"W X 48"H

DANIELS FOOD EQUIPMENT

310 NORTH CLAYBORN AVE. PARKERS PRAIRIE, MN. 56361 PHONE: (218) 338-5000 FAX (218) 338-5909

WEB: www.danielsfood.com

E-MAIL: danielsfood@midwestinfo.net

3/11/2013