

DMX 50 SPECIFICATIONS

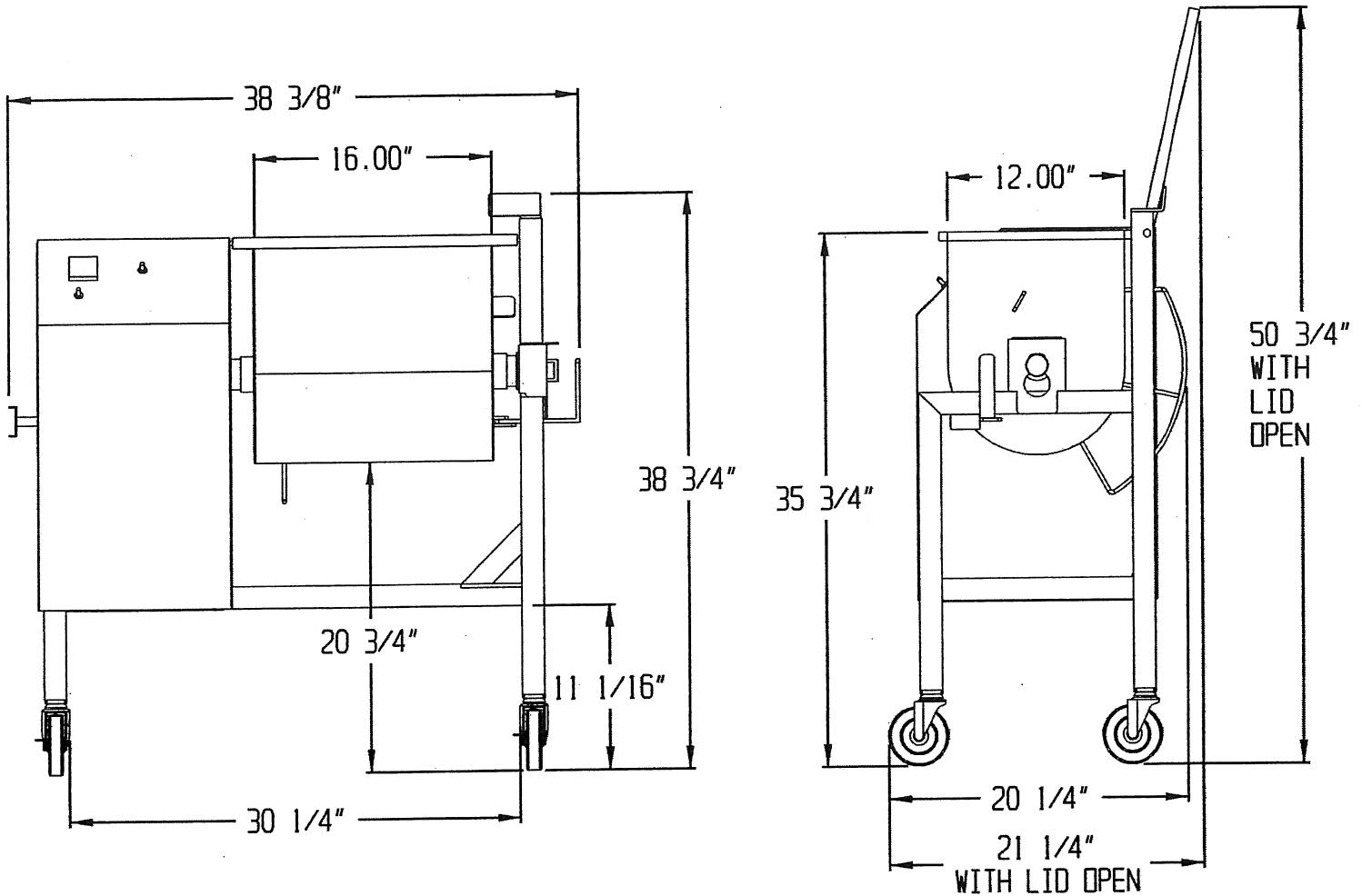

- MOTOR:** STANDARD: 1/2 HP, 1 PH, 115 V, 60 Hz, 10.1 AMP
- PADDLE RPM:** 29 RPM
- DIRECTIONAL CONTROL:** FORWARD – STOP – REVERSE
- HOPPER CAPACITY:** 75 LBS, 50 LBS OPERATING CAPACITY
- CONSTRUCTION:** ALL STAINLESS STEEL, 120° DUMPING, REMOVABLE PADDLE, STAINLESS STEEL COVER, WITH SAFETY LOCKOUT OPEN UNDER HOPPER FOR EASY DUMPING, LOCKING SWIVEL CASTERS
- DUMP HEIGHT:** 16-5/8"
- WEIGHT:** 150 LBS, SHIPPING INFO 200 LBS 26" X 49" X 50" TALL